

Description : COUNTRY FRENCH LADDERBACK
CHAIR WITH WOOD SEAT

Item No. : C-219

Toll Free : 1 888 944 8396

BEFORE ASSEMBLY

Thank you for purchasing this Whitewood Industries Inc.'s quality product. This product has been designed for easy assembly and constructed for durability. Please take the time to read and follow the assembly instructions carefully.

Be sure to check all packing material carefully for small parts, which may have come loose inside the carton during shipment. Please separate, identify, and count all parts and metal hardware. Compare with part list to be sure all parts are present. If a part or hardware is missing or have any difficulties in assembling this product, please contact Toll Free: 1-888-944-8396.

IMPORTANT NOTE:

- Place all wooden parts on a clean and smooth surface such as a rug or carpet to avoid the parts from being scratched.
- Remove all wrapping material, including staples & packing straps before you start to assemble.
- DO NOT tighten all screws, bolts until all completely assembled.
- Keep all hardware parts out of reach of children.

ASSEMBLY TOOLS REQUIRED







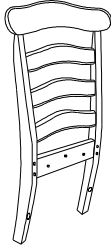
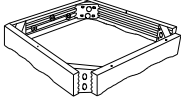
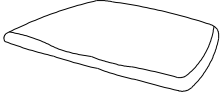
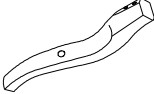
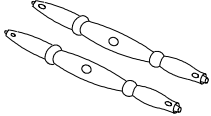
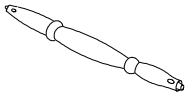

PART LIST

When unpacking, please carefully not to discard any parts with the packaging. Before continuing, please make sure you have all of the following parts:

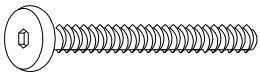
NO	Description	Qty	Sketch	NO	Description	Qty	Sketch
A	Chair back frame	1		B	Seat frame	1	
C	Wood seat	1		D	Front leg (L-R)	2	
E	Side stretcher (L-R)	2		F	Center stretcher	1	

HARDWARE LIST

When unpacking, please carefully not to discard any parts with the packaging. Before continuing, please make sure you have all of the following hardware:

NO	Description	Qty	Sketch	NO	Description	Qty	Sketch
1	Long bolt (M7.8x70mm)	8		2	Short bolt (M7.8x35mm)	3	
3	Lock washer (Φ8xΦ11mm)	11		4	Flat washer (Φ8xΦ19mm)	11	
5	Allen key (4mm)	1		6	Small screw (M4x35mm)	10	

STEP 1

Put parts together as below picture

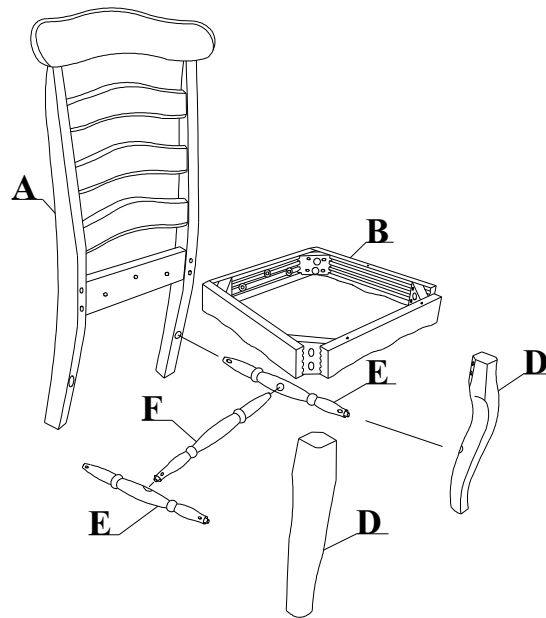

STEP 2

To fix the seat frame (B) with the back frame (A), use washers (3), (4) and bolt (2) with the Allen key (5).

Then fix the seat frame (B) with front legs (D) and back legs on back frame (A), use washers (3), (4) and bolt (1) with the Allen key (5).

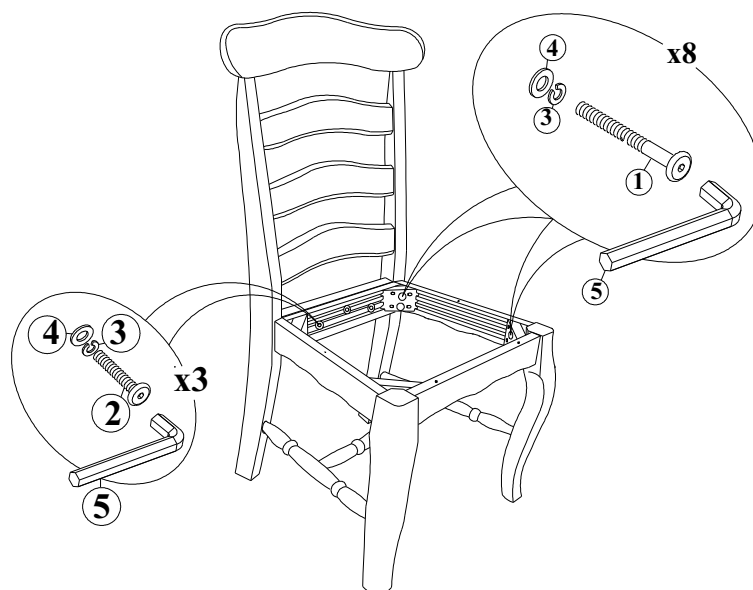

STEP 3

Use a screw driver to fix stretchers (E), (F) together, stretchers with legs, and front apron of seat frame with the seat at underneath.

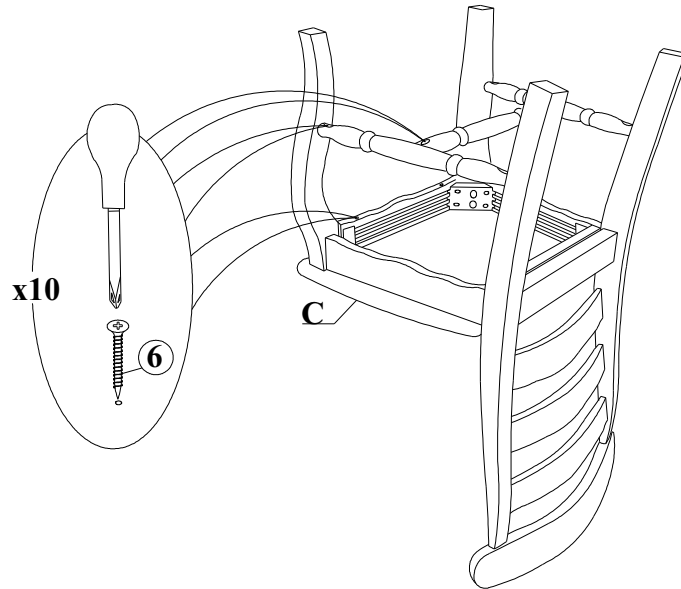

STEP 4

Put the chair on a flat surface, tighten all screws and bolt.

Finish.

